

Heavy Duty Series Below Grade Enclosures

Tier Rated Underground Enclosures for Driveway, Parking Lot, and Off-Roadway Applications

Telecom Vaults Heavy Duty Series below grade enclosures are crafted from an advanced composite using a unique molding and gelcoat process, resulting in enclosures that are both lightweight and durable. These enclosures offer superior ease of handling and installation, with a tapered wall design that maximizes usable volume compared to similar polymer concrete models. Available in 2 rectangle sizes.

The Heavy Duty Series provides additional volume and can be stacked for efficient shipping and storage, reducing freight and handling costs significantly, despite being up to 75% lighter than polymer concrete alternatives. These enclosures maintain a durable gelcoat finish that resists UV damage and hydrolysis.



FEATURES

- Exceeds load testing with ANSI/SCTE-77 for both tier 15 and 22 ratings
- Structurally rugged, non-metallic advanced composite material construction produces enclosures that are durable, lightweight, easy to install, and resistant to chemicals and water
- Tapered wall sides create maximum usable interior space
- Interior walls can support splice case and other mounting brackets using epoxy adhesive kits
- Deep well bottom edges provide long-term stability in grade level placements
- Units available in 2 sizes, both come in either tier 15 or 22 rated
- Stainless steel hardware, including hex-head bolts

APPLICATIONS

- Fiber optic, copper and coaxial slack cable coiling and storage
- Access to sealed cases (splice cases, repeaters, load coils, etc.)
- Meter boxes and Junction boxes
- Irrigation systems and other waterway control valves
- Traffic and railway signal controls
- Ground rods





**HEAVY DUTY
TRUE VAULT SERIES**



CTRUE304836

Appx. Dimensions: 30"Wx48"Lx36"D

Description: Tier 15 & 22 Rated
Gelcoat Composite
30"Wx48"Lx36"D

Unit Weight: T15- 202lb, T22- 212lb
Pallet Weight: T15- 1290lb, T22- 1350lb

Pallet QTY: 6
Truck Load: 120 units

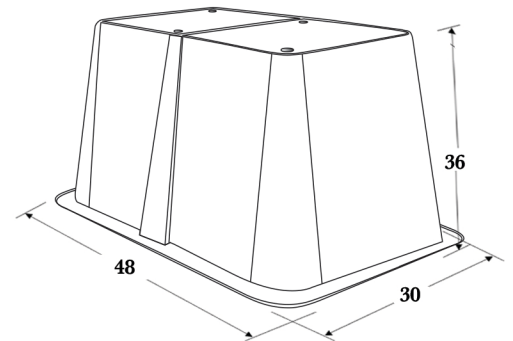

CTRUE306036

Appx. Dimensions: 30"Wx60"Lx36"D

Description: Tier 15 & 22 Rated
Gelcoat Composite
30"Wx60"Lx36"D

Unit Weight: T15- 255lb, T22- 261lb
Pallet Weight: T15- 1095lb, T22- 1120lb

Pallet QTY: 4
Truck Load: 96 units

